



Premium Fuel Injectors



BOSCH

Invented for life

Fuel Systems Expertise

Bosch is a recognized leader in fuel systems technology, with more than 45 years of gasoline injection system experience. Today, Bosch has produced over 1 billion fuel injectors, and has proven to be a reliable partner in fuel system expertise and the number one name in original equipment (OE).

The Bosch Fuel Injection program provides vast coverage for Domestic, European and Asian vehicles. Our global presence means we are familiar with the specific needs of each market and our customers locally, enabling us to meet specific regional requirements.

Our customers know and value us as a reliable partner throughout the complete vehicle lifecycle. We have an in-depth understanding of the overall vehicle system, and we apply and integrate drive technology according to the exact system requirements of our customers.

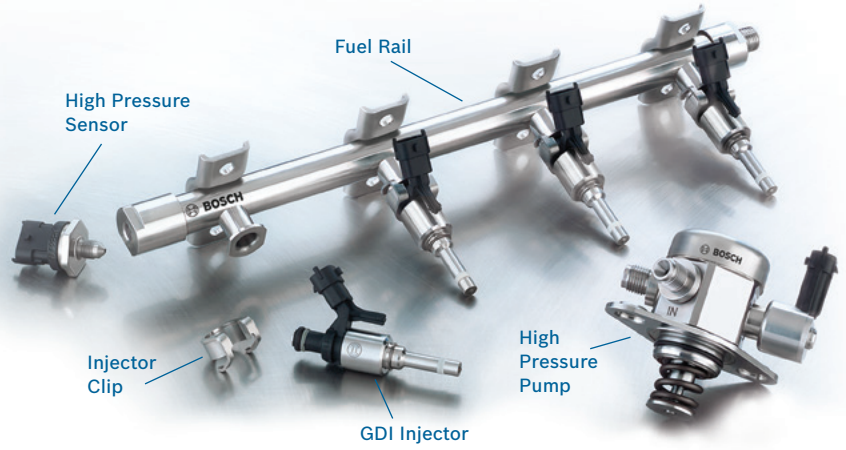

Why Bosch Fuel Injectors?

Bosch Fuel Injectors offer many advantages, including:

- ▶ Eliminating vapor leakage
- ▶ Reducing CO2 emissions
- ▶ Increasing engine output

We also provide many different sizes and types of fuel filters – and variable sizes of (the EV14) injectors, with multiple spray patterns – to cover global platforms and meet the demands of all vehicle makes and models.

Spray Patterns

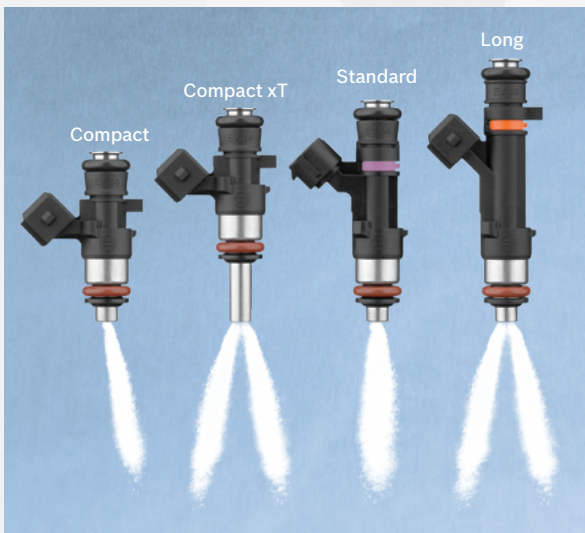

C Type
Gamma
Angle

E Type
2 Spray

C Type
Conical
Spray

E Type
2 Spray

Connector Types

Sumitomo



Jetronic



USCAR



EV6



EV14 (Standard)



EV14 (Compact)



GDI



Port Fuel Injection

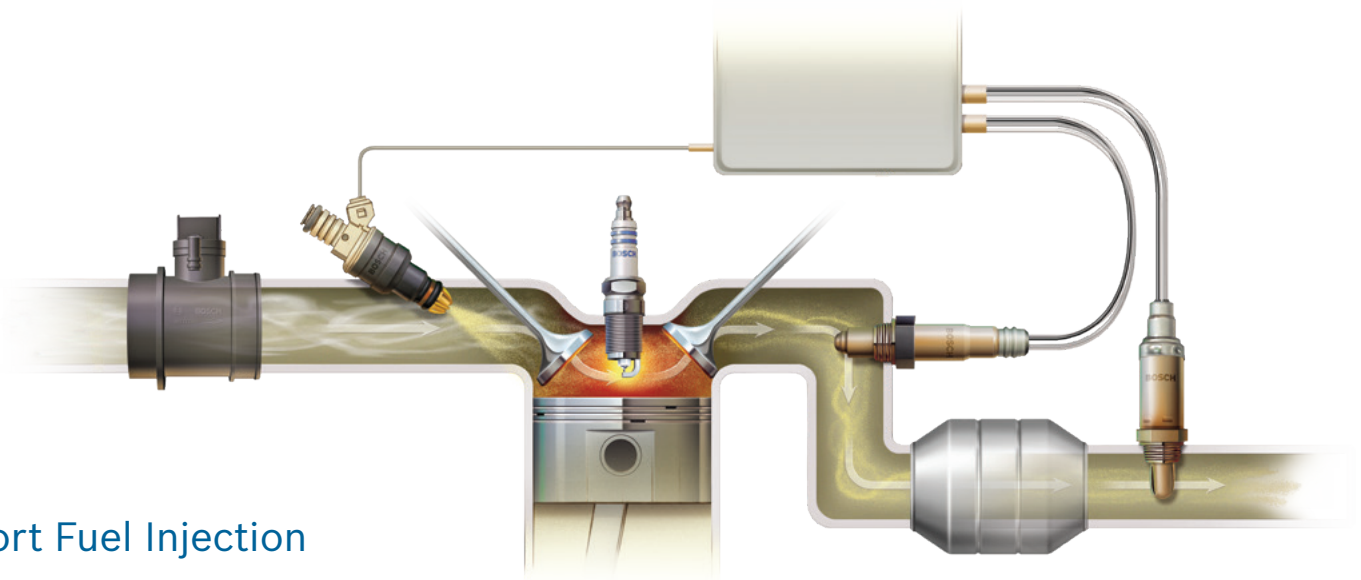

Since 1967, Bosch has engineered port fuel injectors that consistently redefine the standard of gasoline injection systems. Port Fuel Injection (PFI) is the world's most widely-used system for internal combustion engines and offers many benefits for engines with a low pressure output:

- ▶ Low-pressure systems are less complex and more affordable than high-pressure systems
- ▶ A robust combustion process tolerates lower-quality fuel
- ▶ The system's maintenance friendly design reduces the overhead for system diagnostics

Port injectors are positioned outside the combustion chamber – between the Mass Air Flow Sensor and the intake valve – with the tip of the injector sitting outside, pointing towards the combustion chamber. Air and fuel are combined outside the combustion chamber, in the intake manifold. From there, the mixture flows through the intake tract and the intake valve to the combustion chamber.

Advanced Port Fuel Injection

With the development of Advanced PFI, Bosch implemented further improvements to the drive system to reduce fuel consumption and CO₂ emissions and increase engine output. Fewer individual components are required with Advanced PFI – and since there is no high-pressure circuit, no high-pressure fuel injectors are used.

Features

- ▶ Improved spray preparation
- ▶ Worldwide application
- ▶ Flexible installation and spray characteristics for every engine
- ▶ Advanced ball and cone valve seat
- ▶ Strong, one-piece shell
- ▶ Refined spray pattern
- ▶ Reduced CO₂ Emissions

Benefits

- ▶ Reduces emissions
- ▶ Ensures global coverage for all makes and models
- ▶ Meets the demands of all vehicle makes
- ▶ Eliminates vapor leakage to lower emissions
- ▶ Provides better performance under all driving conditions
- ▶ Eliminates exposed metal
- ▶ Improves mixture and combustion
- ▶ Boosts gasoline engine efficiency

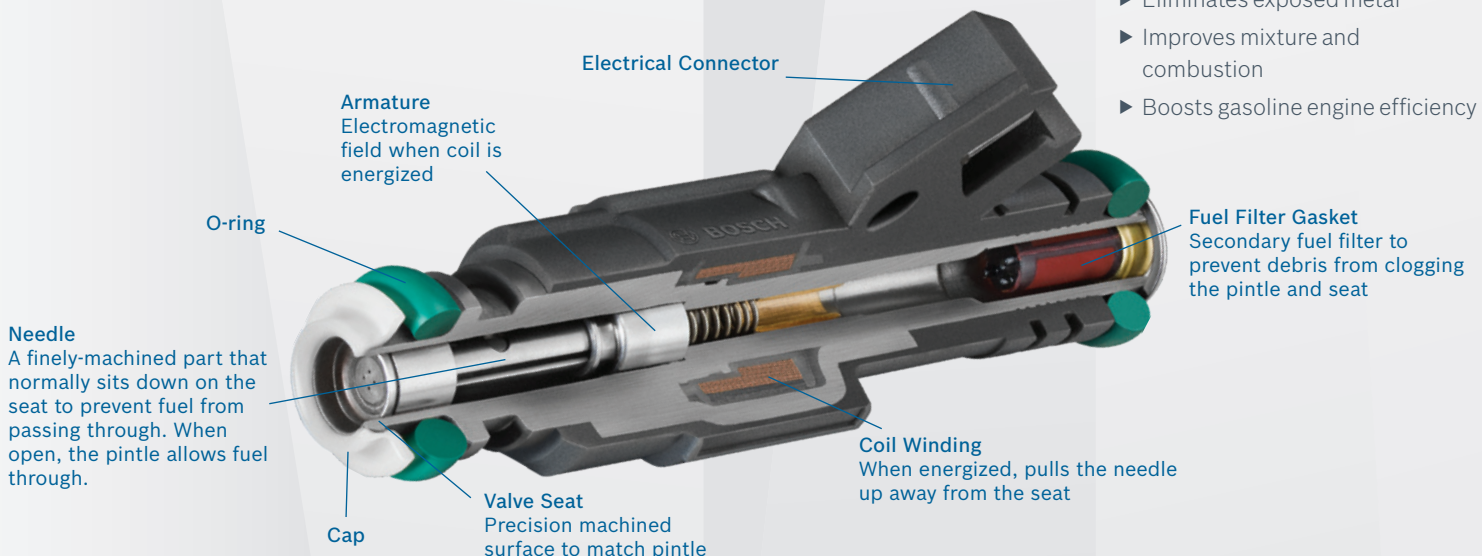

Gasoline Direct Injection

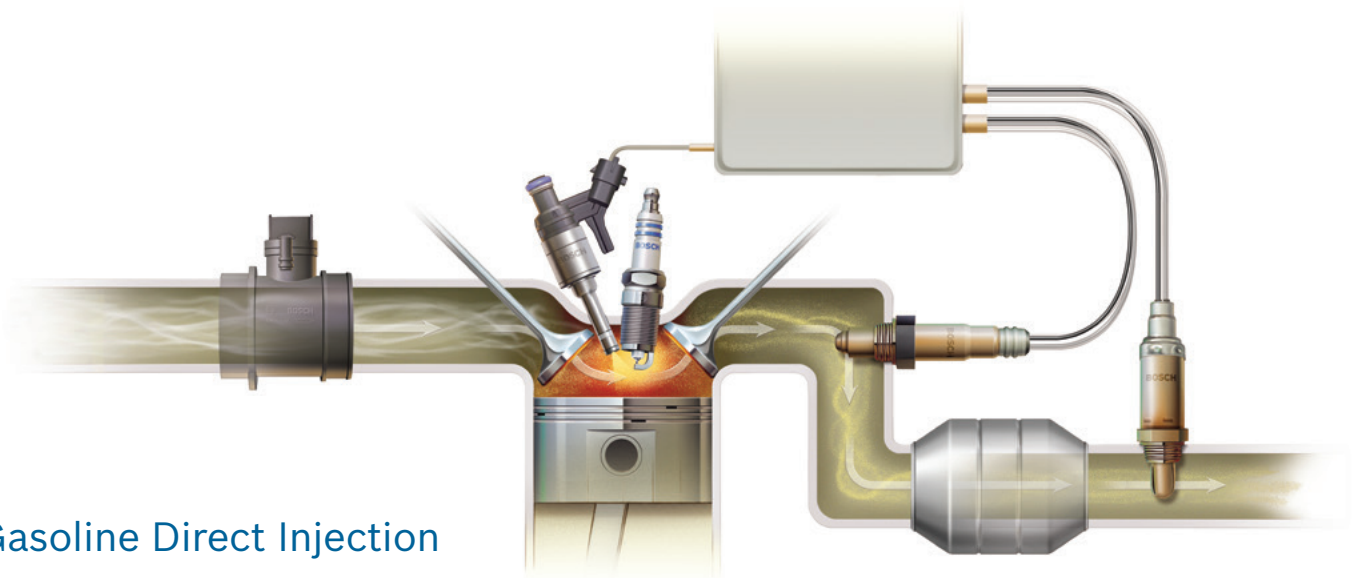

Since launching Gasoline Direct Injection (GDI) in 1951, Bosch has strengthened its position as a pioneering force in fuel systems technology by providing the most economic combustion for the gasoline engine to date.

It is predicted that by 2020 a quarter of all vehicles will be equipped with GDI technology – which aids in reducing engine size, while maintaining performance and increasing miles per gallon (MPG). By injecting a precise amount of fuel directly into the combustion chamber, fuel waste is minimized – producing outstanding performance and unmatched fuel economy.

GDI injectors are positioned in the cylinder head with the tip of the injector located inside the combustion chamber, spraying fuel directly into the combustion chamber at pressures of up to 2900 psi. This eliminates any wall wetting, which is the collection of fuel on the walls of the cylinder head that can lead to emissions issues. GDI spray patterns are also conical but target the piston. These two components are designed together to create the best flame propagation possible within the cylinder. This is an effective means of reducing fuel consumption and emissions, while greatly boosting driving dynamics. GDI systems also deliver higher performance and higher efficiency compared to port systems. Like all GDI products, the High Pressure Pump is manufactured from stainless steel—offering high-fuel compatibility worldwide.

Did you know?

Today, **over 15%** of cars on the road are equipped with GDI.

By 2025, **over 40%** of cars on the road will be equipped with GDI.

Because GDI provides the basis for a cleaner, more economical engine generation it is expected to maintain a significant growth in the coming years. As more vehicle manufacturers start series production of engines equipped with direct injection, the market for these systems will rise. This increase will create demand for high-quality maintenance and repair tasks in the aftermarket.

All Bosch fuel injectors released to the aftermarket are engineered for OE fit, form and function because they are produced to OE specifications.

Features

- ▶ High pressure fuel injected directly into combustion chamber
- ▶ Synergies with turbocharging
- ▶ Homogeneous and lean-burn combustion
- ▶ Key enabler for engine downsizing, while maintaining desired horsepower

Benefits

- ▶ Boosts fuel savings up to 15%
- ▶ Increases low-end torque up to 40%
- ▶ Supports all specified fuels
- ▶ Improves efficiency and reduces carbon emissions



Tips & Tricks

Don't Clean it – Replace it!

Many injector testers have a cleaning function, which can eliminate some deposits. But cleaning multi-point and high-pressure injectors can cause:

- ▶ Failures from aggressive additives in the cleaning fluid
- ▶ Thermal damage to the solenoid as a result of incorrect triggering currents
- ▶ Voided warranty claims or part guarantees



Pic A



Pic B



Pic C

A) Dirty spray-orifice disk of an injector before cleaning

B) Spray-orifice disk after cleaning; not all deposits were removed

C) Clean spray-orifice disk of a new injector

While no maintenance is needed on injection components themselves, keeping fresh clean gasoline in the fuel tank and changing the in-line filter per the manufacturer's recommendations are good practices.

Ensuring Optimum Performance

Fuel injectors are an essential engine component. Malfunctions can lead to serious engine damage – which is why faulty injectors have to be identified and replaced as quickly as possible. Only properly functioning injectors can provide motorists with an assurance of:

- ▶ Minimized fuel consumption
- ▶ Significantly improved starting performance
- ▶ Immediate acceleration
- ▶ Longer service life for exhaust components

Tips & Safety Precautions

Always follow the vehicle manufacturer procedures for servicing a vehicle and its related components to avoid personal injury and/or damage to system components.

- ▶ Receive the proper training before attempting to service any fuel injection system.
- ▶ Ensure the system pressure has been relieved before performing any work on the vehicle. Technicians should follow the vehicle manufacturer's recommended procedure for this or any other task.
- ▶ GDI injectors are driven by higher voltages and larger currents than port fuel injectors. As such, isolation of the technician from the electrical circuit is very important.

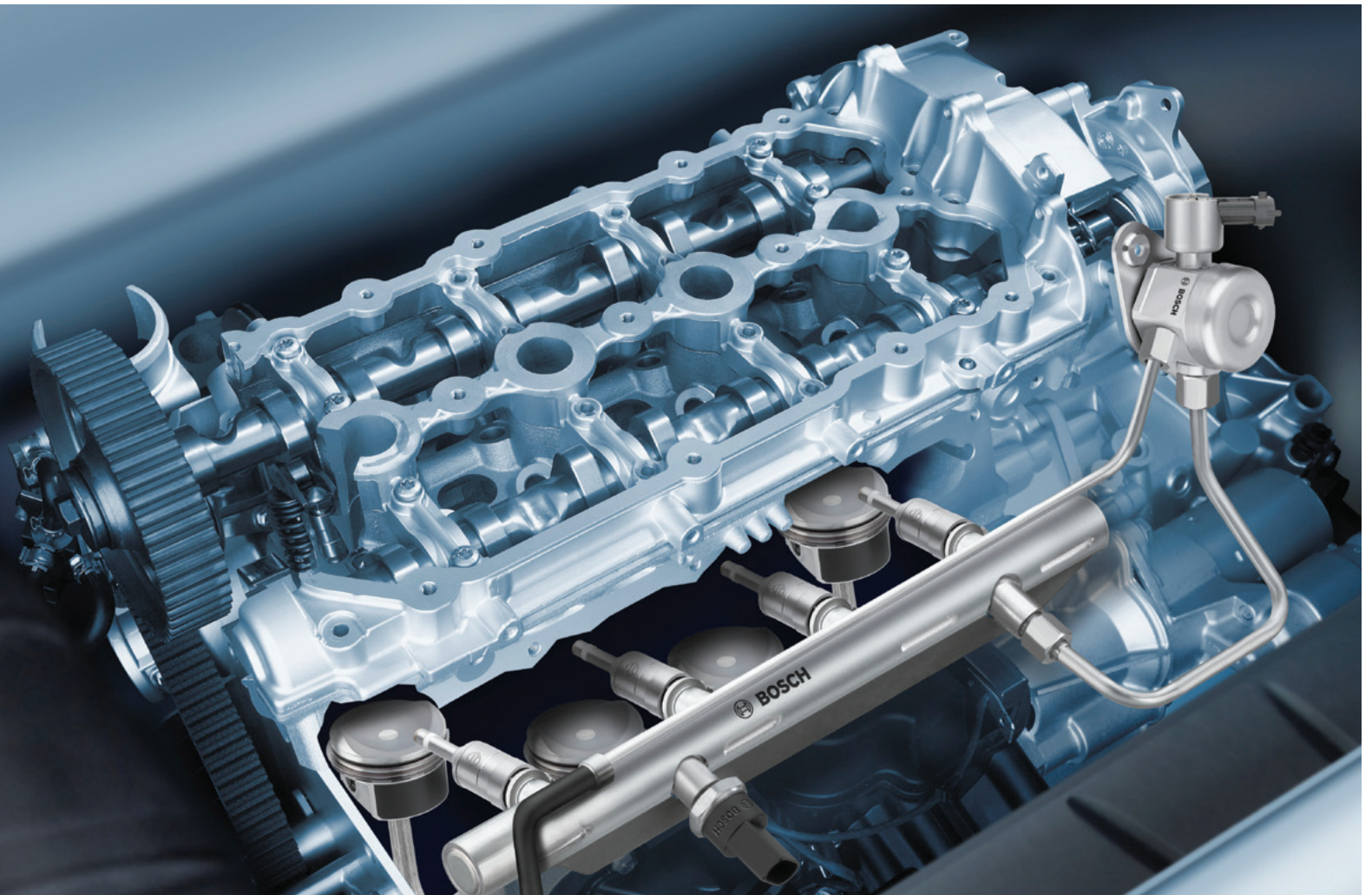

Superior Functionality

Bosch Fuel Injectors provide high-quality functionality, including:

- ▶ Optimum spray pattern for perfect mixture generation and efficient combustion, even for dynamic driving
- ▶ Low consumption and emissions, particularly in the starting and warm-up phase
- ▶ Improved cross-sections inside valves for outstanding warm-start performance
- ▶ Optimum corrosion resistance due to high-alloy steels and plastic covering

Aftermarket Offerings

Bosch Fuel Injectors offer the aftermarket:

- ▶ The broadest and greatest market coverage
- ▶ Easy and secure ordering with reliable application data
- ▶ Simple, reliable installation
- ▶ Original equipment quality, leak-free fitting and minimal function tolerances

Technology Upgrades for Older Vehicles

Bosch is continuing its heritage of innovation by expanding its large line of fuel injector application coverage to include even more models – allowing technicians to put brand new technology into new and old vehicles.



BOSCH

Invented for life

Robert Bosch LLC
Broadview, Illinois 60155

Robert Bosch, Inc.
Mississauga, Ontario L5N 1R1

www.boschautoparts.com
www.boschautoparts.ca

1806030

©2018 Robert Bosch LLC, USA. All rights reserved. BOSCH is a registered trademark of Robert Bosch GmbH and/or its affiliated entities.